

CONSTRUCTION ENGINEERING



ABOUT US

LBYD was founded in 1973 with the incorporation of E. Glenn Bishop & Associates. In 1978, with the merger of the structural engineering firm Lane & Hodnett Structural Engineers, the firm became Lane/Bishop/Hodnett, Inc. In 1987, with the addition of Dale York and Jim Delahay as Principals, the firm became LaneBishopYorkDelahayInc, known today as LBYD, Inc.

In 2001, LBYD began offering civil engineering services. With the addition of the civil department and the continued commitment of our structural department, LBYD has experienced phenomenal growth. We continue to pursue growth opportunities evidenced by opening the Huntsville office in 2009, the Tampa Bay office in 2011, the Auburn office in 2017, and the Nashville office in 2018.

In November 2020, LBYD merged into North Wind Group as a subsidiary company.

LBYD is part of a family of companies with common ownership under Cook Inlet Region, Inc. (CIRI)—an ANC. The North Wind family, comprised of 17 companies, is managed by North Wind Group, a CIRI government contract holding entity. Under North Wind Group, all 17 companies share the same proven corporate infrastructure (i.e., Health and Safety, Quality Programs, human resources, accounting, contract management, project controls) that has been in place over 25 years successfully completing a combined total of over \$2.4B for 35 offices/districts/ sites within 11 Federal agencies and commercial entities through various contract types including firm fixed price (FFP) indefinite delivery/indefinite quantities (IDIQs). This group of companies provides significant flexibility and diversity, enabling us to effectively meet and exceed customer requirements and expectations through significant reach-back to resources within our own organization.

LBYD is certified by the National Minority Supplier Development Council (NMSDC) as well as the Southern Region Minority Supplier Development Council (SRMSP). LBYD is a minority and economically disadvantaged business (SDB) by statute under 43 U.S.C. § 1602 and 1626(3)(1) & (2) and further codified under 13 C.F.R. § 124.109(a)(2) due to our ANC ownership by CIRI, as determined by the National Congress of American Indians (NACI). In addition, LBYD is a Small Business (SB) per the Small Business Association.





LARGE FIRM EXPERTISE, SMALL FIRM RESPONSIVENESS

Large Firm Expertise, Small Firm Responsiveness has become a staple across our company and is present in the work we do on a daily basis. Starting out as a small one-person firm, and growing to over one hundred engineers, we have provided engineering services for various clients including architects, engineers, contractors, commercial developers, public and private institutions, as well as local, state and federal governments.

OUR PROJECTS

LBYD provides civil and structural engineering services on a wide variety of project types for architects, engineers, contractors, commercial developers, public and private institutions and local, state and federal governments. Our project experience includes libraries, educational facilities, sports fields and complexes, public parks, office complexes, parking garages, hospitals, mixed-use facilities, convention centers, bridges, stadiums, arenas, correctional facilities, manufacturing and industrial facilities, residential buildings, residential subdivisions, municipal consulting and government facilities.



OUR SERVICES

STRUCTURAL ENGINEERING

Our structural engineers are knowledgeable in the development of different framing schemes and foundation designs using a wide variety of construction materials for determining the most economical and constructible structural systems.

CONSTRUCTION ENGINEERING

We understand that connection design must be safe and must be economical for the fabricator and erector to produce. We work closely with fabricators to provide designs that work well with the fabricator's shop practices and can be erected in the field as easily as possible.

HYDROLOGY AND WATER RESOURCES

We offer comprehensive hydraulic and hydrology engineering services to ensure quality corrective and preventative measures for stormwater drainage.

STORM SHELTERS

We design storm shelters within schools and other structures to withstand loading from tornadoes and heavy winds in accordance to ICC 500, and safe rooms according to FEMA P-361.

INDUSTRIAL APPLICATIONS

We work with industrial clients to identify the problem they are facing, understand the processes that are in place in the facility, and create a custom solution around it to make sure the facility meets their exact needs.

CITY ENGINEERING

Our engineers can assist municipalities in all areas of city engineering including development plan reviews, roadway inventories and resurfacing schedules, stormwater management and permitting, public works manuals, parks and recreation design, capital improvement plans, funding assistance, and more.

CIVIL ENGINEERING

Our work includes site grading, storm water management, best management practices, erosion and sediment control, utility design which includes gravity sanitary sewer designs, wetland mitigation, flood plan modifications, stream impacts, on-site sewage disposal, and earthwork calculations.

TEMPORARY STRUCTURES

We design and verify the structural capacity of temporary structures such as tents, temporary grandstand seating, stage platforms, etc.

PEER REVIEWS

Peer reviews can include interviews, review of documents obtained during the review process and technical reviews.

FORENSICS

We offer innovative and economical investigative and corrective design services in areas such as site placement, foundation failures, roofing and envelope investigations, storm damage, earthquake and vibration damage, truss failures, concrete failures, expert testimony and litigation support, and more.

PARKING

LBYP is a leader in the design of parking facilities in the Southeast. We have designed parking facilities for federal facilities, government facilities, institutional facilities, office buildings, churches, hospitals, mixed-use facilities, commercial buildings, and residential buildings.

SUSTAINABLE DESIGN

LBYP is a Founding Member of the Alabama Chapter of U.S. Green Building Council. We have designed many facilities that have earned LEED certifications.

LICENSED LOCATIONS

LBYD has engineers currently registered in multiple states across the country, but we are continually expanding our licensure as needed.

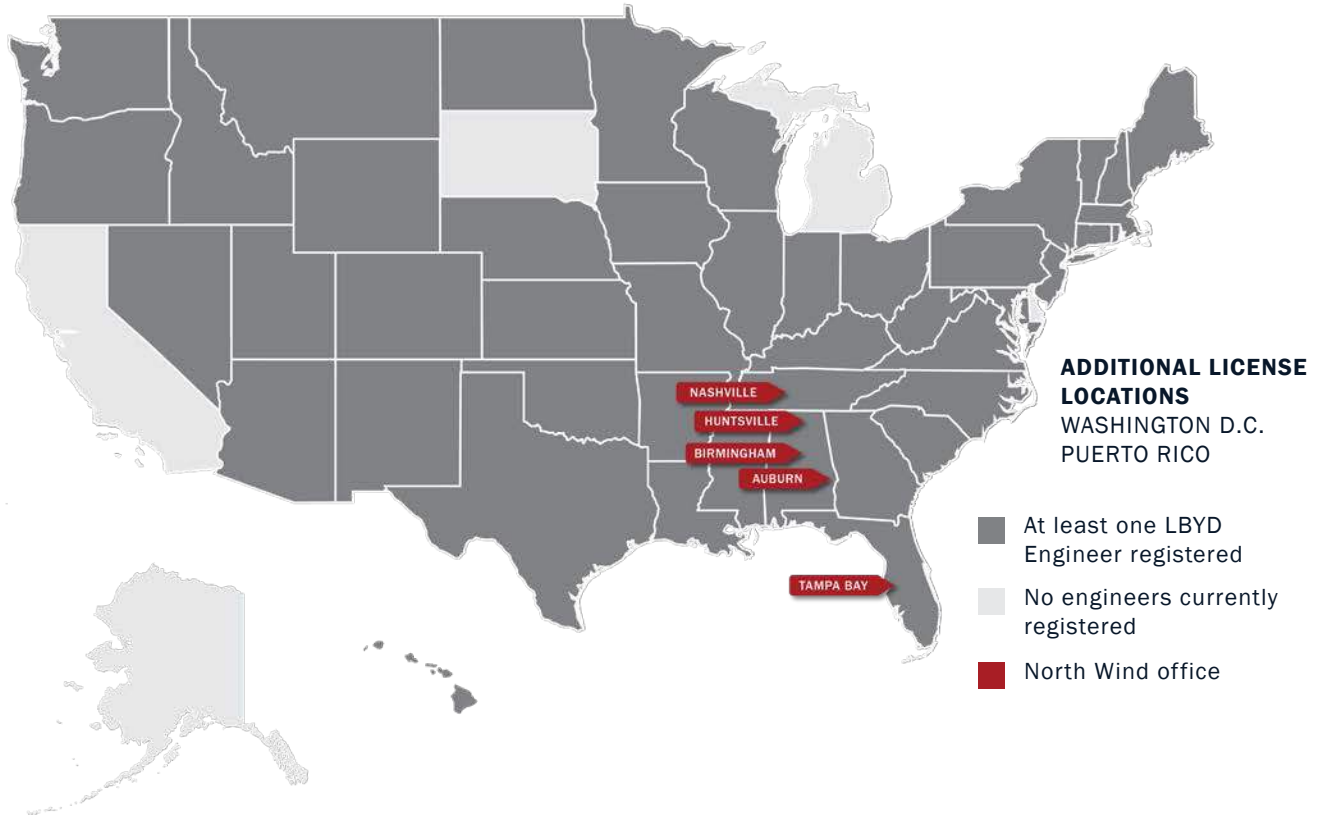

LEADERSHIP



BRAD CHRISTOPHER, PE
PRESIDENT / SENIOR PRINCIPAL ENGINEER

Brad Christopher is the President & General Manager of LBYD, Inc. and Engineering Group President. He graduated from Auburn University where he received his Bachelor's and Master of Science degrees in Civil Engineering. Brad has over 30 years of design experience covering new construction, renovation, and additions to existing structures for institutional, athletic, commercial, municipal, and industrial uses. He is registered as a professional engineer in 10 states.

Brad is an active member of the Auburn University Engineering Alumni Council, the American Concrete Institute, the International Code Council, Inc., and the Structural Engineers Association of Alabama. He has also served on the Board of Directors for the Structural Engineers Association of Alabama, and Auburn University Civil Engineering Advisory Board, and annually assists with the senior civil engineering design class at Auburn University. Brad has authored three articles for Structure Magazine on economical concrete construction.



ROBERT WHYTE, PE, SE
PRINCIPAL ENGINEER/CONSTRUCTION ENGINEERING DIVISION MANAGER

Robert Whyte has provided structural designs for numerous projects throughout North America. Through the development of these projects, he has gained valuable experience in the design of structural steel, metal fabrications and multi-story concrete, steel, wood, and masonry buildings. As Principal Engineer, he is experienced in the review of construction submittals and shop drawings, as well as on-site observations during construction. His design experience includes numerous structural steel connection design projects, specialty stair and handrail, industrial, institutional, new construction, and renovations and additions to existing structures. He has also written several articles and delivered presentations related to structural steel connection design.

Robert has over 25 years of Structural Steel and Connection Design experience and is licensed as a Professional Engineer (PE) in over 15 states and Structural Engineer (SE) in Illinois.



CONSTRUCTION ENGINEERING

LBYD's Construction Engineering Division bridges the gap between what is shown on the Contract Documents and the design needs of the General Contractor.

Our staff has intimate knowledge of how buildings and other structures are designed across all building materials. This gives us the unique advantage to efficiently communicate with the Structural Engineer or Architect to bring their vision and design intent to fruition.

Working on the contracting side of the fence we are quite accustomed to react quickly to schedule demands.

LBYD has a team of specialty engineers with over 25 years of experience in the industry.

We can provide services as Specialty Structural Engineering Services (SSE) for Delegated Design items or work directly to support the General Contractor during construction.

STRUCTURAL STEEL CONNECTION DESIGN

Structural steel connections can have elaborate loading and complex geometry. LBYD has extensive knowledge of steel connection design, fabrication practices, and steel detailing. We work closely with steel detailers, fabricators, and erectors to provide designs that work well with the fabricator's shop practices and can be erected in the field safely and efficiently.

Our staff has over 25 years of experience in the industry and have authored many publications and given seminars on connection design topics. Our capacity allows us to take on projects large & small with a dedicated team for your project.

Our standards and deliverables have been proven to be cost-effective and easy to understand to the user – from the Steel Detailer to the Structural Engineer of Record (SEOR).

We employ the latest 'state-of-the-art' software in our design; however, our experience also allows us to work on highly-complex joints outside of the limits of any design software. Our software capabilities include:

- Ram Connection
- Idea Statica
- Trimble Connect / Tekla Structures
- Qnect Collaboration

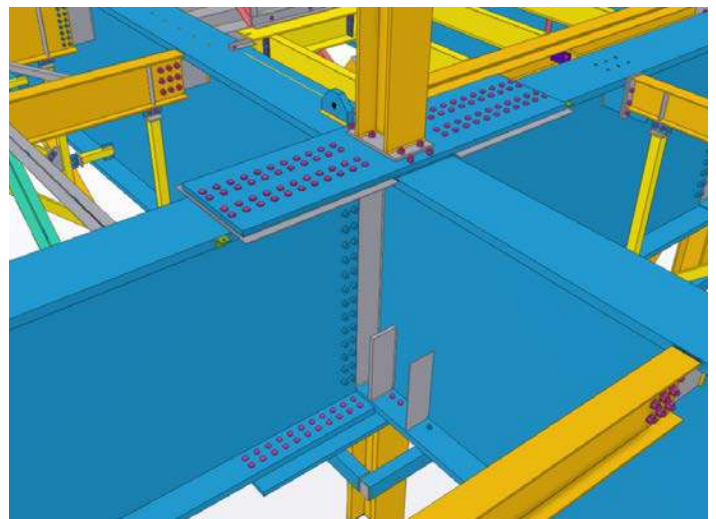
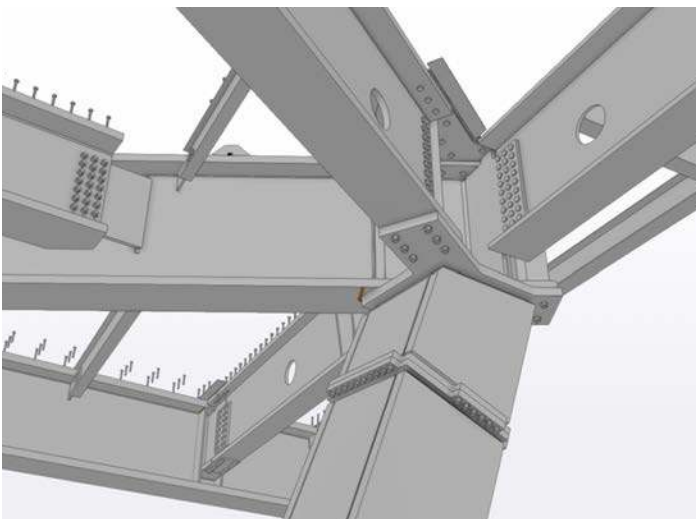
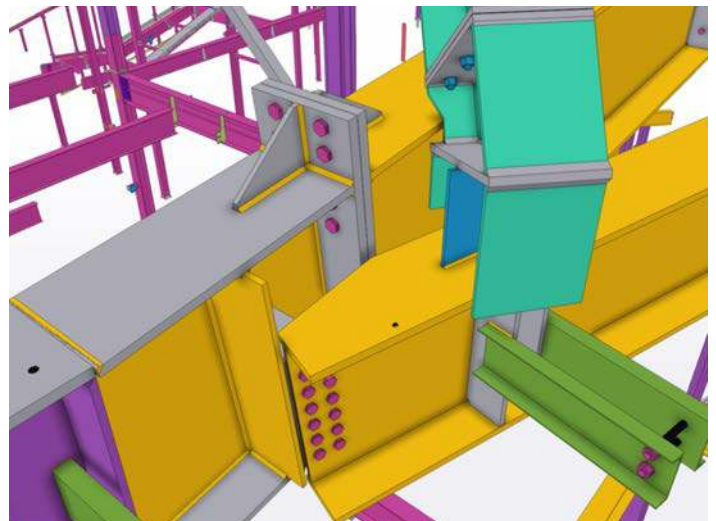

TEMPORARY STRUCTURES & SCAFFOLDING DESIGN

Temporary structures often require specialized design to facilitate repeated erection and disassembly while also optimizing pieces for shipping and handling. LBYD has extensive experience in the design of temporary structures ranging from construction sites to sporting events.

We leverage our experience in building design, aluminum structure design, and erection engineering to provide the design that best fits the needs of the owner and the erector. Our temporary structure experience includes:

- Hospitality structure design
- Scaffold design
- Temporary grandstand design
- Temporary seating support design



Topgolf Live at Jordan-Hare Stadium

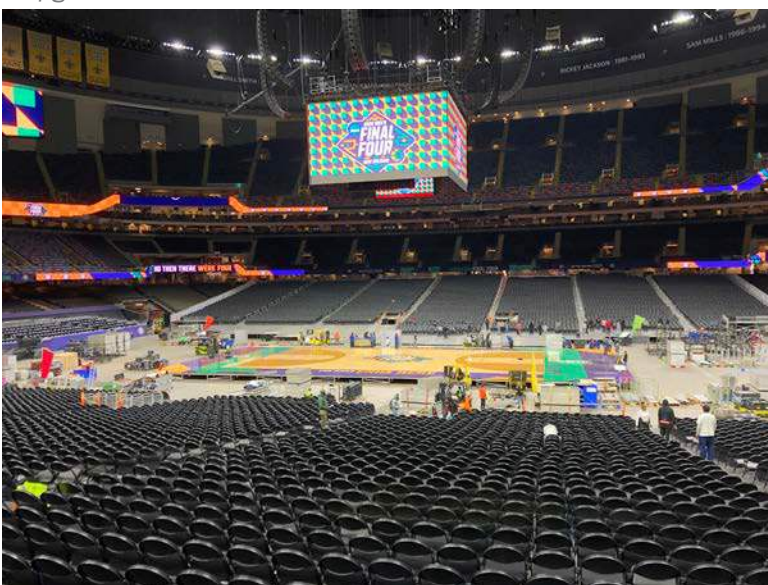

NCAA Final Four Seating

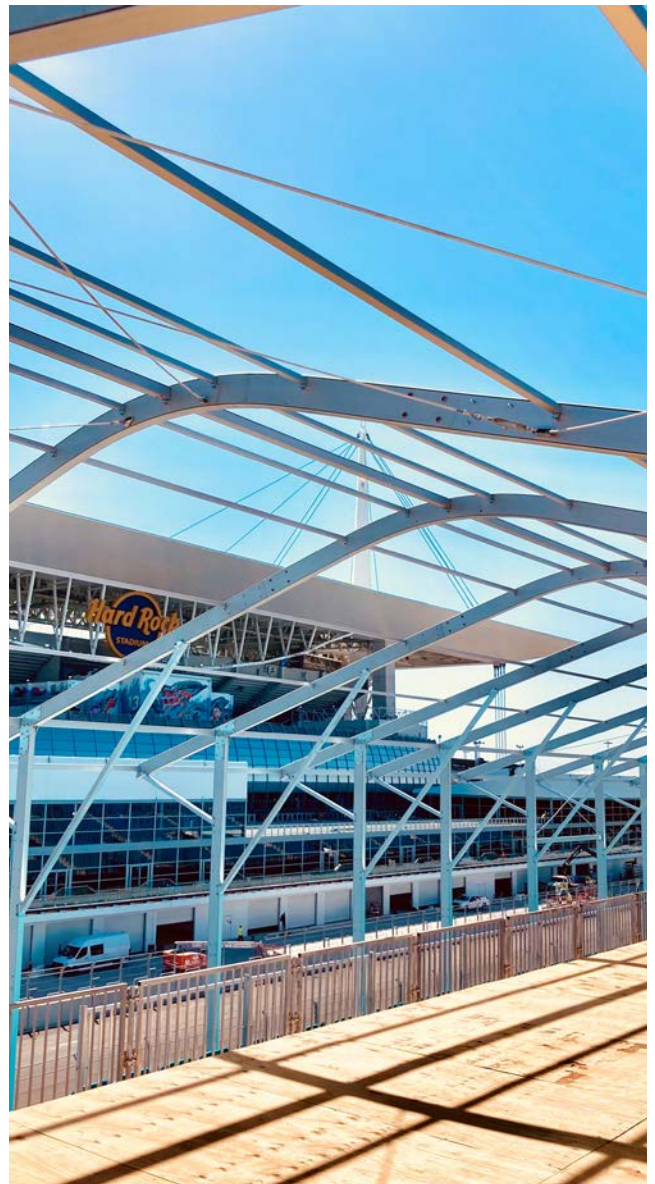

Miami Grand Prix Seating

ENHANCED STEEL INTEGRATION (ESI)

Structural steel can often be the contractor's largest purchase throughout the construction of a building. Enhanced Steel Integration (ESI) is a project delivery method where LBVD coordinates with a steel detailer during the design phase to provide a partially connected steel detailing model alongside the construction documents.

We leverage our experience in building design and steel connection design to jumpstart the detailing of the primary structural steel and its connections while construction documents are still in design. The ESI steel model is a fabrication level model ready for architectural, MEP, and miscellaneous steel coordination immediately upon receipt of the construction documents.

The ESI project delivery method reduces RFIs, accelerates submittal reviews, tightens steel bids, and shortens the time from NTP to steel fabrication. Any project with steel on the critical path should consider the ESI project delivery method with LBVD.

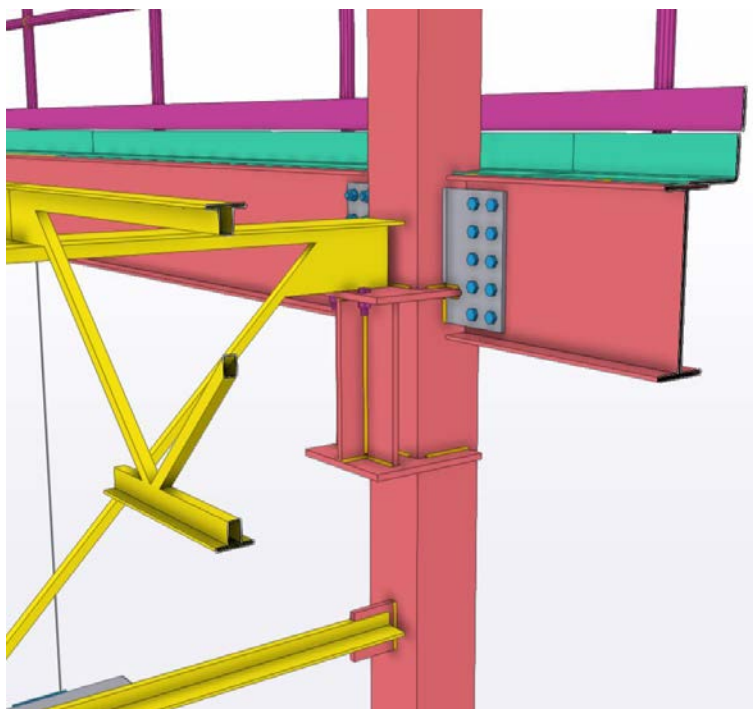
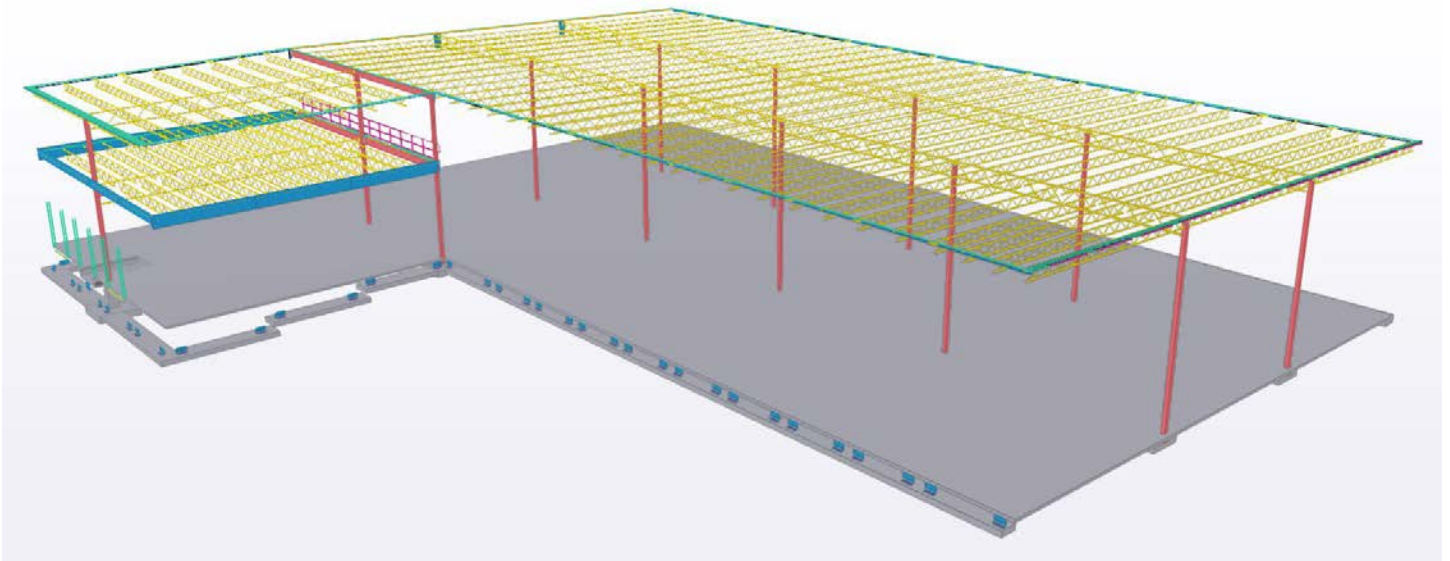

ERECTION ENGINEERING

During construction environmental loads, such as wind and seismic, are typically not considered by the Structural Engineer of Record. LBYD has experience working with the General Contractor and the Steel Erector to provide engineering support for the stability of the structure during these temporary loading conditions. Below is a listing of our Erection Engineering services:

- Staging plans showing crane locations
- Temporary bracing plans and connection design
- Lifting plans and rigging
- Critical lift plans
- Shoring design & foundations
- Dunnage/cribbing design
- Lifting lug design
- Spreader beam design



Alabama A&M Events Center

ADDITIONAL SERVICES

Aluminum Structures Design

LBYD provides design support to aluminum fabricators that primarily service the water and wastewater industry. We assist the fabricators with their shop drawings and provide calculations for structures such as stairs, mechanical platforms, and handrail in aluminum.

Wall Shoring Design

Walls built from Concrete Masonry Units (CMU) or Cast-in-Place Reinforced Concrete may often require to be shored for lateral loads such as wind or seismic. LBYD can work with the subcontractor to provide the shoring design for these walls including attachments and specifying 'dead men' or other types of anchoring.

Cold-Formed Metal Framing Design

The structural back-up for a façade is routinely provided by cold-formed metal framing (metal studs). These systems are often a Delegated Design item and are designed to withstand lateral loading such as wind and seismic, but they must also be stiff enough for the deflection requirements of the outside veneer shown on the architectural drawings. LBYD works with metal stud suppliers to provide drawings for submittal to the Structural Engineer of Record for cold-formed metal framing systems. We also can provide design of 'load-bearing' systems where the metal studs are also supporting the gravity system of the structure.

CONTACT US



880 MONTCLAIR ROAD, SUITE 600
BIRMINGHAM, AL 35213



(205) 251-4500



MARKETING@LBYD.COM



LBYD.COM

